

SUMMARY		Page
I	INTRODUCTION.	1
II	STV5712/STV5715 APPLICATION.	1
III	STV5712/TEA5705 APPLICATION.	3
IV	PCB LAYOUT PATTERN	6
V	SILKSCREEN PRINTING PATTERN	6

I - INTRODUCTION

ONE PCB, TWO APPLICATIONS,
MANY OPTIONS.

To take advantage of the pin to pin compatibility of the 2 heads video amplifier STV5715 with the 4 heads video amplifier TEA5705 is the guideline of this demoboard.

With one PCB two main applications can be realized :

- STV5712/STV5715 providing a 2 video/2 FM audio playback/record solution
- STV5712/TEA5705 providing a 4 video/2 FM audio playback/record solution.

Additionally the PCB layout of the board offers the user several application options as desired.

II - STV5712/STV5715 APPLICATION

The Demoboard is mounted according to the typical application diagram (Figure 1).

Regarding the STV5715 part, V_{R1} and V_{R2} trimmers have been added in order to easily adjust the record signal to the required level.

Supply Voltages

	STV5712	STV5715
Playback Mode	$V_{CC} = 5V$	$V_{CC} = 5V$
Record Mode	$V_{CC} = 5V$	$V_{CC} = 5V$ and $5V < V_{REC} < 12V$

Application options provided by the PCB layout

Figure 2 gives an example of electrical diagram using the PCB options.

- STV5712 part :
 - C109/C110 capacitors can be added to tune the head peaking effect,
 - C105/C112 capacitors can be added to filter the control signals (only when disturbances can be noticed)
- STV5715 part :
 - C24/C25 can be added to tune the head peaking effect,
 - using Q2, Q3, R15, R16, R17, R18 circuitry, the STV5715 can be supplied with a single 5V line in record mode.

STV5712 - STV5715 - TEA5705 DEMOBOARD

Figure 1 : STV5712/STV5715 Typical Application

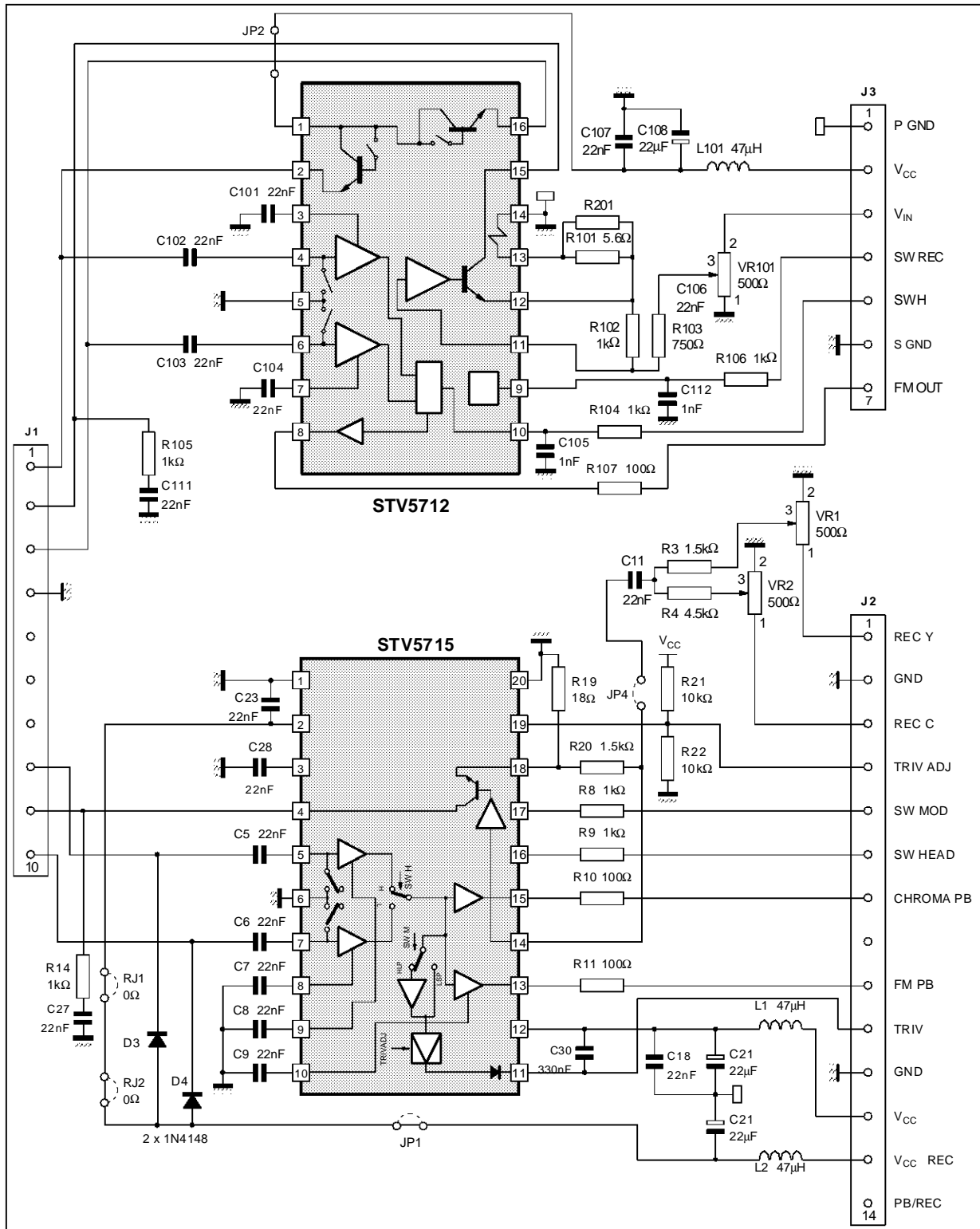
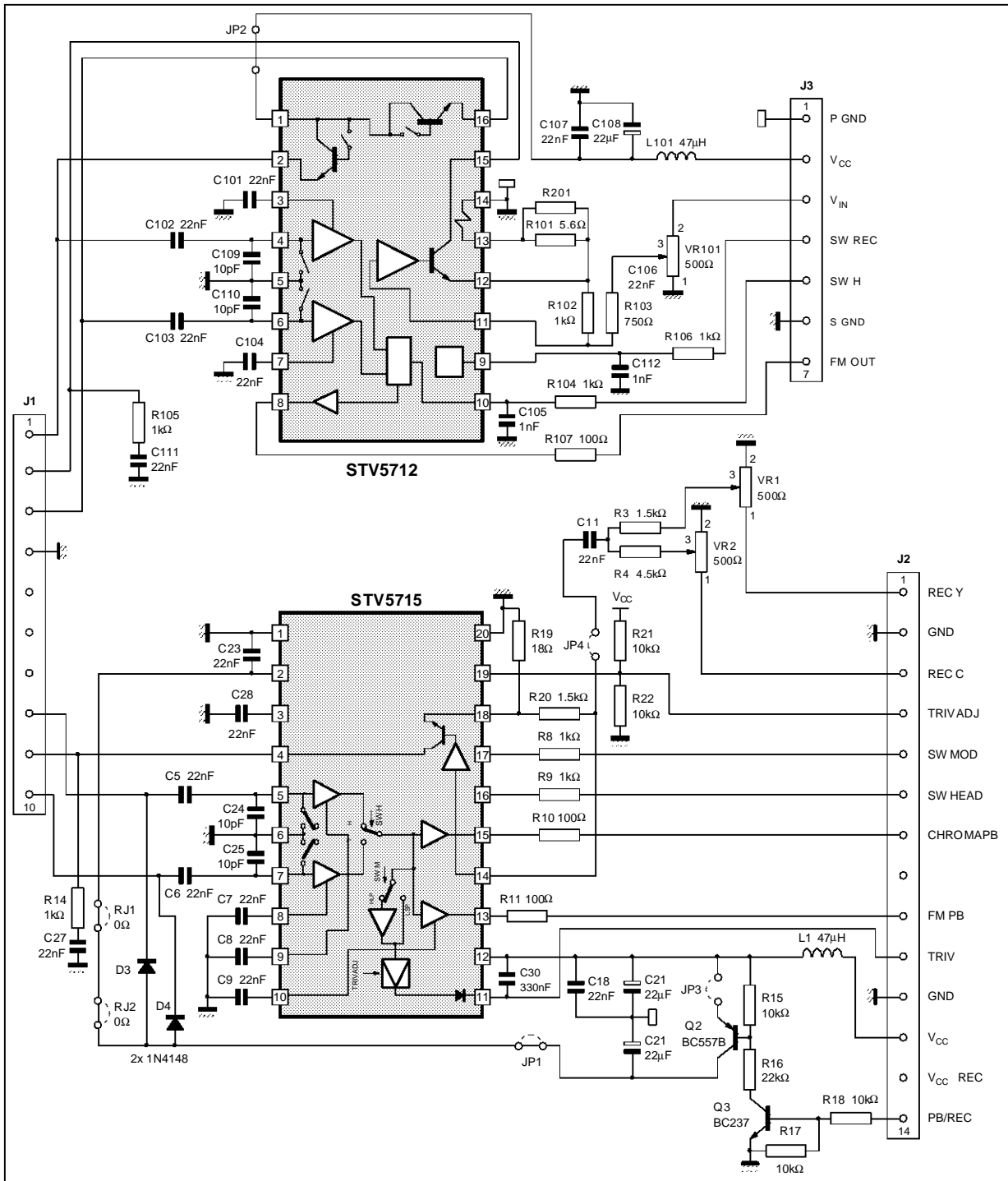

Figure 2 : STV5712/STV5715 Application Example using the PCB Layout Options



III - STV5712/TEA5705 APPLICATION

The demoboard is mounted according to the typical application diagram (Figure 3).

Similarly to the STV5715, VR₁ and VR₂ trimmers

have been added in order to easily adjust the record level to the required level.

Supply Voltages

As STV5712/STV5715 application

STV5712 - STV5715 - TEA5705 DEMOBOARD

Figure 3 : STV5712/TEA5705 Typical Application

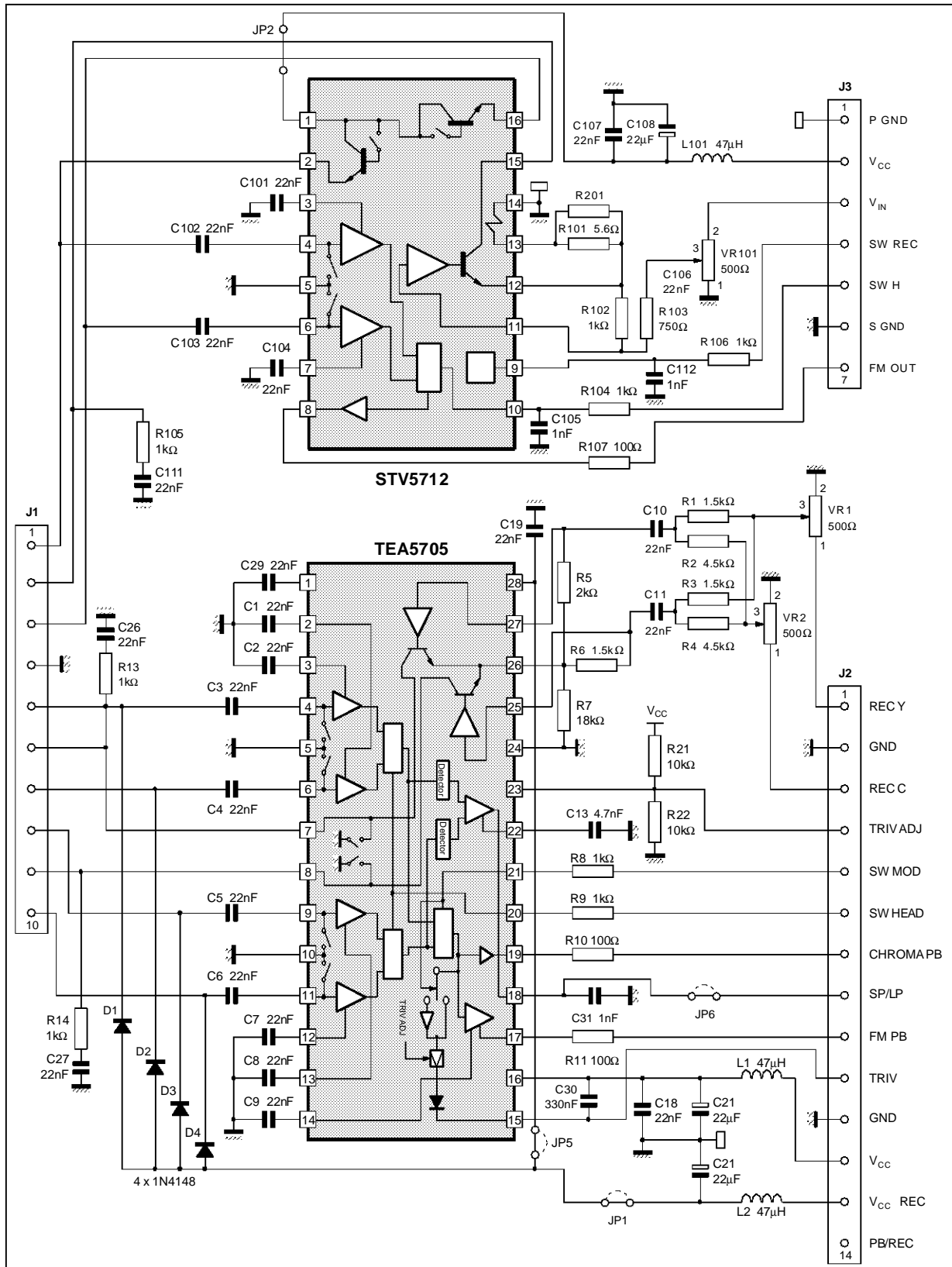

AN629-03.EPS

STV5712 - STV5715 - TEA5705 DEMOBOARD

Application options provided by the PCB layout

Figure 4 gives an example of electrical diagram using the PCB options.

- STV5712 part : see chapter II

- TEA5705 part :
 - C22/C23/C24/C25 can be added to tune the head peaking effect,
 - using Q2, Q3, R15, R16, R17, R18 circuitry, the TEA5705 can be supplied with a single 5V line in record mode.

Figure 4 : STV5712/TEA5705 Application Example using the PCB Layout Options

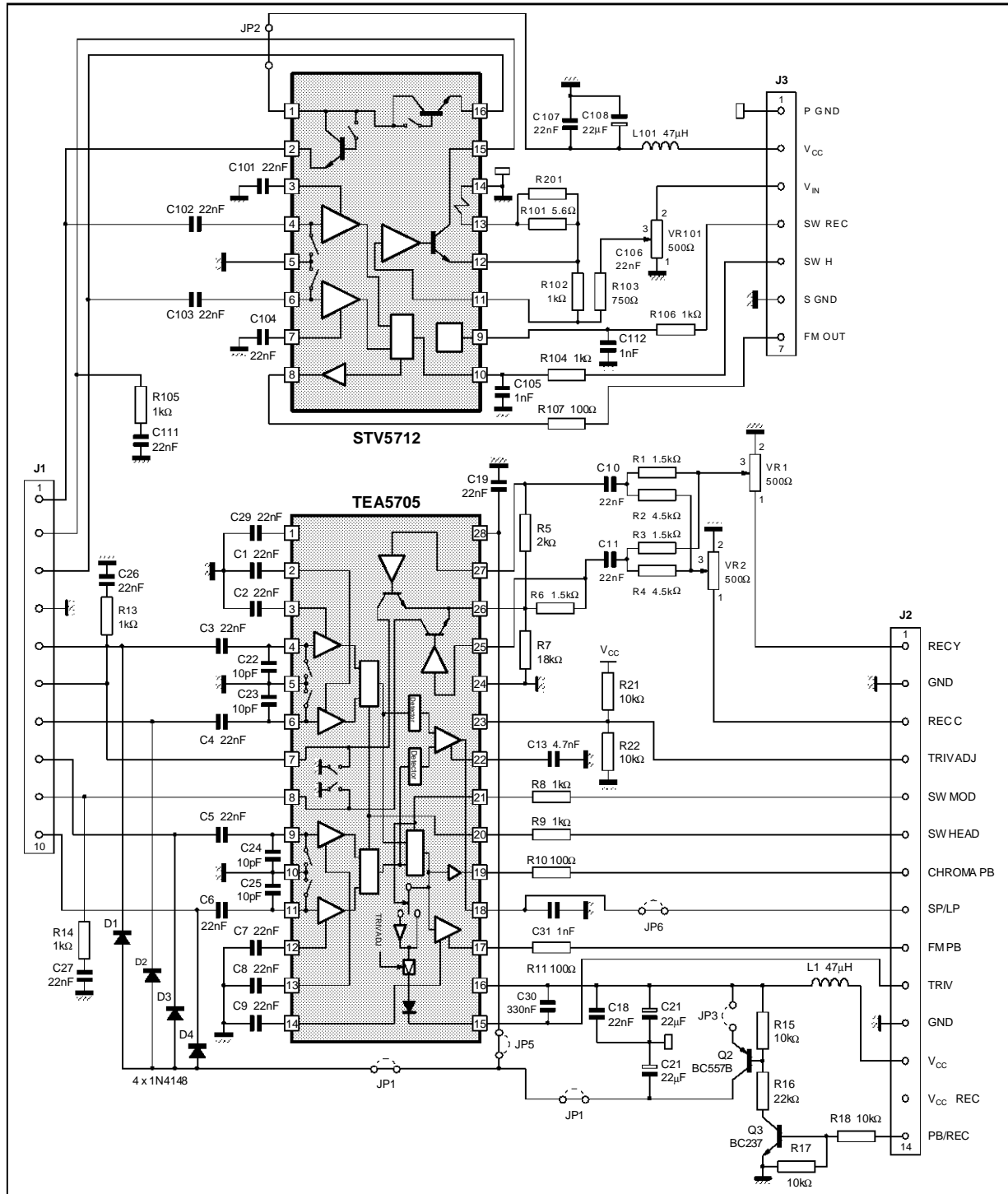

ANG29-04.EPS

STV5712 - STV5715 - TEA5705 DEMOBOARD

IV - PCB LAYOUT PATTERN (copper side)

Figure 5

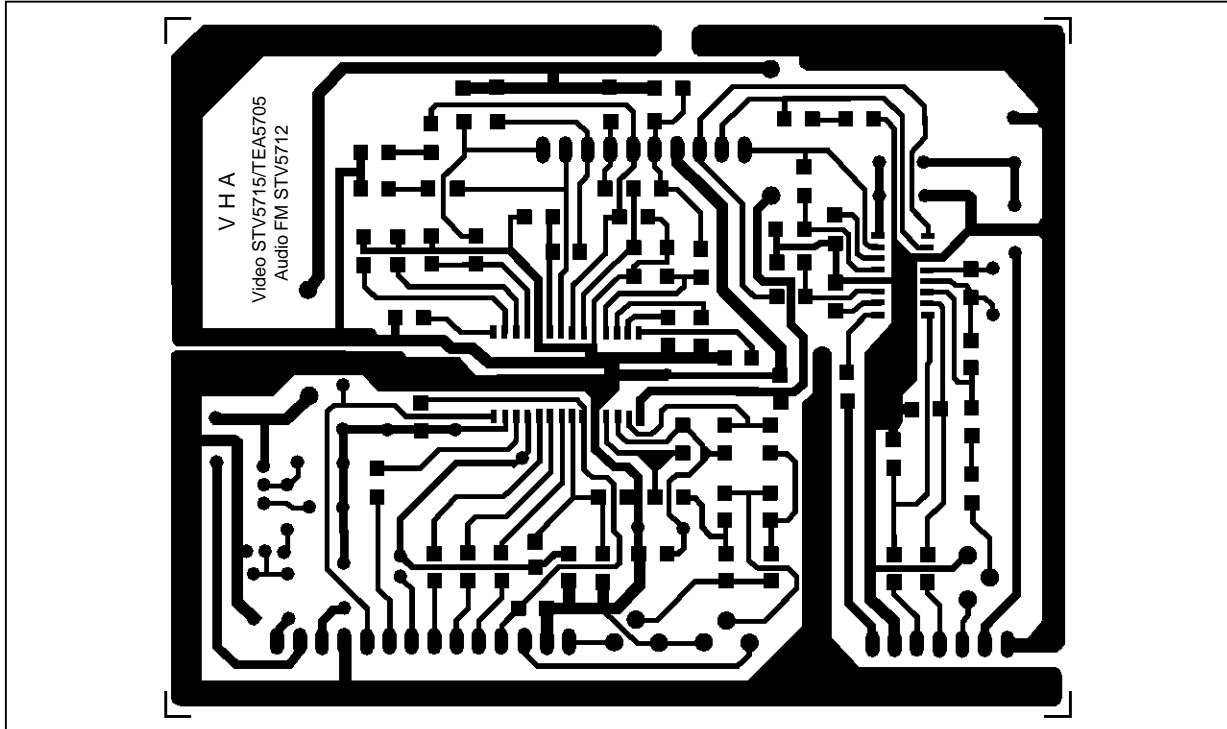

AN629-05.EPS

V - SILKSCREEN PRINTING PATTERN (connectors side)

Figure 6

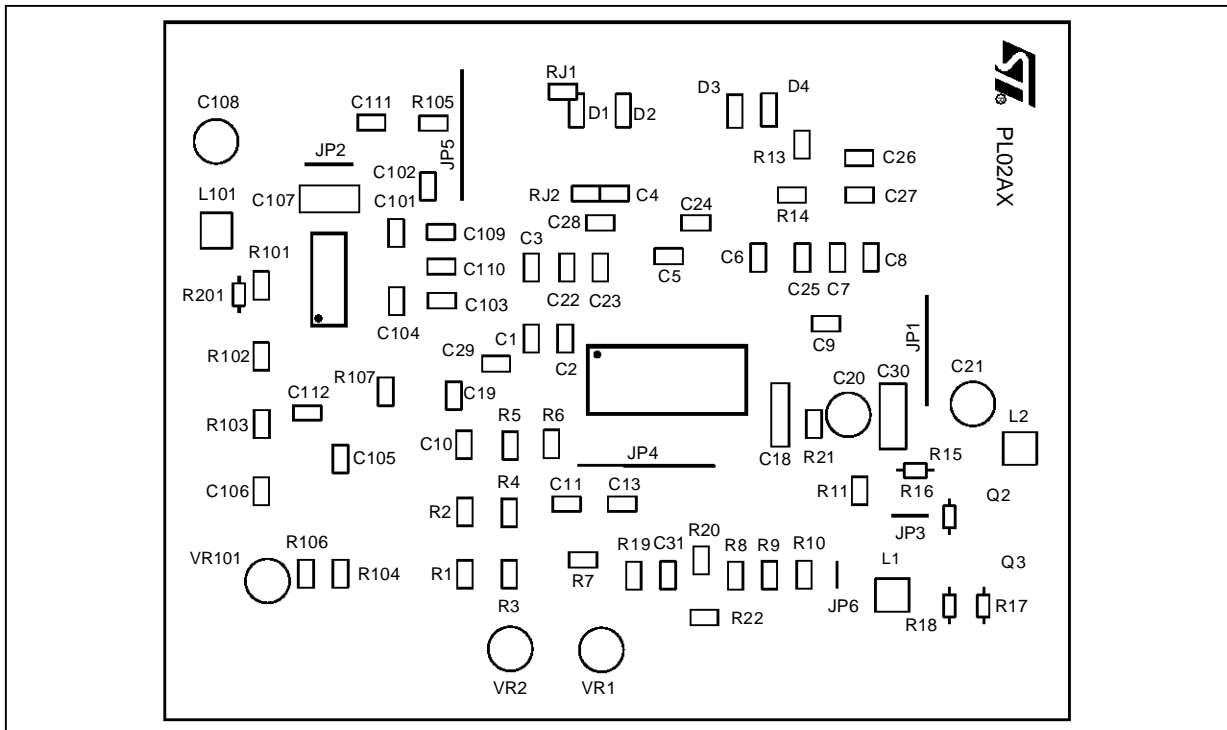

AN629-06.EPS

Information furnished is believed to be accurate and reliable. However, SGS-THOMSON Microelectronics assumes no responsibility for the consequences of use of such information nor for any infringement of patents or other rights of third parties which may result from its use. No licence is granted by implication or otherwise under any patent or patent rights of SGS-THOMSON Microelectronics. Specifications mentioned in this publication are subject to change without notice. This publication supersedes and replaces all information previously supplied. SGS-THOMSON Microelectronics products are not authorized for use as critical components in life support devices or systems without express written approval of SGS-THOMSON Microelectronics.

© 1994 SGS-THOMSON Microelectronics - All Rights Reserved

Purchase of I²C Components of SGS-THOMSON Microelectronics, conveys a license under the Philips I²C Patent. Rights to use these components in a I²C system, is granted provided that the system conforms to the I²C Standard Specifications as defined by Philips.

SGS-THOMSON Microelectronics GROUP OF COMPANIES

Australia - Brazil - China - France - Germany - Hong Kong - Italy - Japan - Korea - Malaysia - Malta - Morocco
The Netherlands - Singapore - Spain - Sweden - Switzerland - Taiwan - Thailand - United Kingdom - U.S.A.